

Pressure Gauge for OF cable



Outline and feature of the product

This product is a pressure gauge with alarm contacts for oil regulating tank, which is used for the OF cable for ultra-high voltage power transmission. This pressure gauge indicates the pressure of insulating oil or insulating gas in the cable, and outputs an alarm when the pressure exceeds the specified range.

◆ Specification

Size	φ 100 or φ 150
Shape	Type B (Circular rim type)
Connector Screw	Connector for electric wire (55° taper)
Accuracy of indication	Class 1.0
Contact Specifications	<ul style="list-style-type: none"> • 2 contacts of upper limit and lower limit with 2 terminals • 2 contacts of upper limit and lower limit with 3 terminals • 3 contacts of upper limit, lower limit, and lowest limit with 4 terminals • Independent 2 contacts of lower limit, and lowest limit with 4 terminals • 2 contacts of lower limit and lowest limit with 3 terminals • Independent 3 contacts of upper limit, lower limit, and lowest limit with 6 cores cord • 2 contacts of upper limit and lower limit with micro-switches • Without contact • Differential pressure gauge with 2 contacts of upper limit and lower limit with 3 terminals

※ This product can be manufactured on various specifications according to order.

◆ Fig.

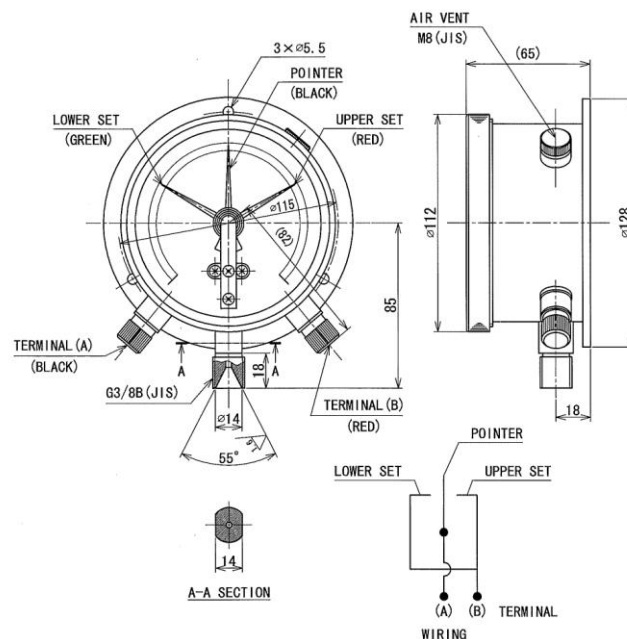

For further information:

Shinagawa Sokki Mfg. Co., Ltd.
 2-16, Omori-minami 1-chome, Ota-ku, Tokyo 143-0013
 Phone : +81-3-3745-0011 FAX: +81-3-3745-0015
 URL : <http://www.shinagawasokki.co.jp>