

# Oil relief valve



Relief Valve used in the sealing oil unit of generator  
 This product is used in the sealing oil unit of the hydrogen cooling type generator in power stations operated by combined cycle method, and to prevent pressurization to the oil flow inlet of the Differential pressure regulator keeping the pressure at the oil pump discharge port at an optional fixed value.

## ◆ Example for Specifications

TYPE	ORV-65A
Maximum flow rate	350 L/min
Ordinary flow rate	220~340 L/min
Adjusting range of operation	0.54~0.88 MPa
Operating accuracy	±5%
Size of flange	JIS B 2220 16K 65A
Ambient temperature	40 ~65°C
Valve type	single valve disc
Weight	Approx.17kg
TYPE	ORV-40A
Maximum flow rate	160 L/min
Ordinary flow rate	60~150 L/min
Adjusting range of operation	0.54~0.82 MPa
Operating accuracy	±5%
Size of flange	JIS B 2220 16K 40A
Ambient temperature	40 ~65°C
Valve type	single valve disc
Weight	Approx.17kg

## ◆ Fig. Type : ORV-65A

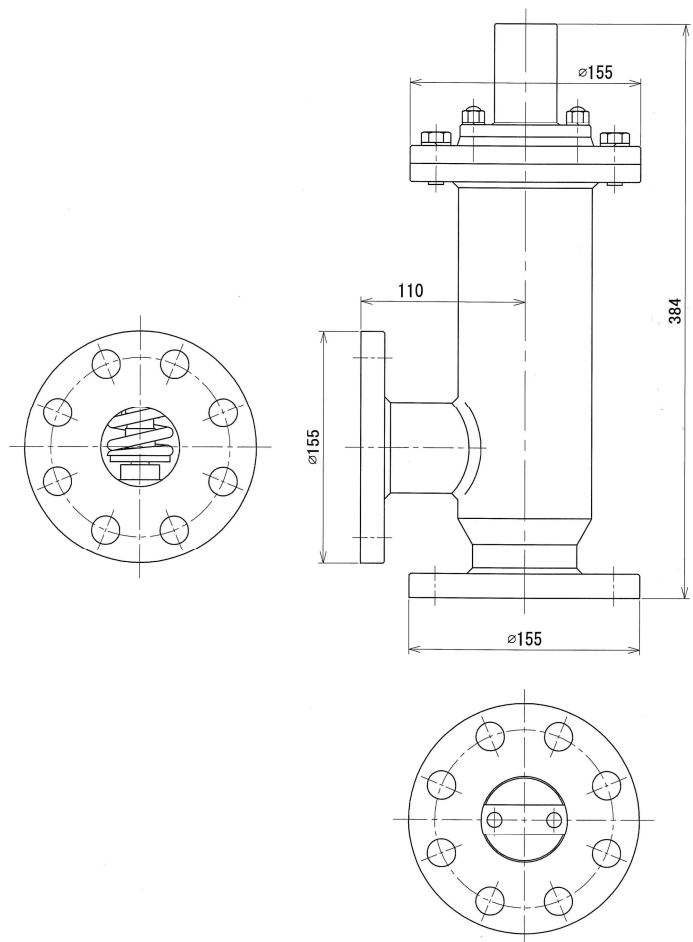

### For further information:

Shinagawa Sokki Mfg. Co., Ltd.  
 2-16, Omori-minami 1-chome, Ota-ku, Tokyo 143-0013  
 Phone : +81-3-3745-0011 FAX: +81-3-3745-0015  
 URL : <http://www.shinagawasokki.co.jp>